

EZCOM-1

PLC - to - AMS MESSAGE DISPLAY INTERFACE

INSTALLATION AND OPERATING INSTRUCTIONS

Rev 1.3 - March, 2001

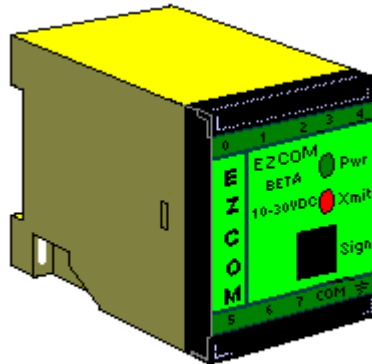

CONTENTS

INTRODUCTION

Page

1

SPECIFICATIONS

1

LIST OF SUPPLIED ITEMS

1

INSTALLATION & TESTING

2

OPERATION

3

Warranty

4

APPENDIX A

Multiple Display Connection

INTRODUCTION

*Information contained herein is subject to prior notification

Filename Quick Reference

change without

© **Adaptable Sign Solutions**, 2001

Website: <http://skybusiness.com/adaptable>

P.O. Box 5239, Mordialloc Victoria 3195, AUSTRALIA ph: 61 3 95909393 fax: 61 3 95909394 e-mail: thorncom@netlink.net.au

INTRODUCTION

This manual outlines the Installation and Operation of the *EZCOM-1* Alpha and *EZCOM-1* BETA Interface units. These devices are designed to interface any PLC to the Electronic Message Centers, or Displays, manufactured by Adaptive Micro Systems Inc, USA. The *EZCOM-1* Interface Units will work with all Displays that conform to the EZ-KEY II Communications Protocol, Version 2.0.

Essentially, the *EZCOM-1* unit takes care of the complicated serial communication necessary to display a particular message. The PLC simply needs to provide a Digital Output* that corresponds to a pre-programmed file in the Display, and the *EZCOM-1* runs the desired message.

*Digital Outputs can be Voltage-Free, Relay Contact or Source -Transistor types.

Note: Messages are pre-programmed into the AMS signs via the IR-Program Loader or the AlphaNet for Windows software.

SPECIFICATIONS

Model Variations

Model	Protocol	Suitable Displays	AMS Cables required
EZCOM-1 Alpha	RS485	Alpha	1088-8625 or 1088-8627
EZCOM-1 BETA	RS232	Alpha, BETABRITE	1088-8625 or 1088-8627

Input Specifications

MODEL	PARAMETER	MIN	MAX	OVERLOAD
EZCOM-1 (BOTH)	Input Voltage	10 VDC	30 VDC	50 VDC
	Input Current	3.8mA @ 10V	12.9mA @ 30V	
	Isolation Voltage	5kVrms for 10s	5kVrms for 10s	
	Temperature	0°C	75°C	
	Response Time*	4msec	6msec	

*Response of EZCOM-1 to change of Input.

Note: Allow for the amount of time it takes to display your message before selecting the next message.

LIST OF SUPPLIED ITEMS

The equipment you should have received follows:-

1. EZCOM-1 Interface Unit. Check which of the 2 models has been supplied.
2. This Installation Manual

Note: AMS Cables are not included in this product.

Note: Wiring to PLC terminals is strictly the Customer's Responsibility, only authorised personnel to install.

Note: Earlier models of the AMS signs required for a jumper to be placed on a pair of pins within the sign. Signs supplied from 1997 did not require the jumper. If you have an old sign, or are not sure, contact our Office.

INSTALLATION & TESTING

Cabling between the PLC and the **EZCOM-1** is not supplied, however we've provided the wiring diagrams to make it easier. 1mm² diameter cable is suitable for shorter distances between the PLC and the **EZCOM-1**. To obtain access to all of the messages that can be stored within the AMS Display will require 8, digital-outputs from your PLC. Ideally, the PLC outputs should be 24VDC, Source-Transistor Outputs, but voltage-free relay contacts switching 24VDC work just as well.

Observe wiring regulations and **DO NOT** run cables from PLC to **EZCOM-1** past Electric Motor wiring or other sources of induced "voltage spikes".

Using the appropriate AMS cable, either the 1088-8625, or the 1088-8627, signs can be from 25' to 50' away. The **EZCOM-1 BETA** is suitable for these applications.

For applications involving more than one sign, the **EZCOM-1 Alpha** can communicate on a network up to 1.2km in length.

EZCOM to PLC Wiring Diagram

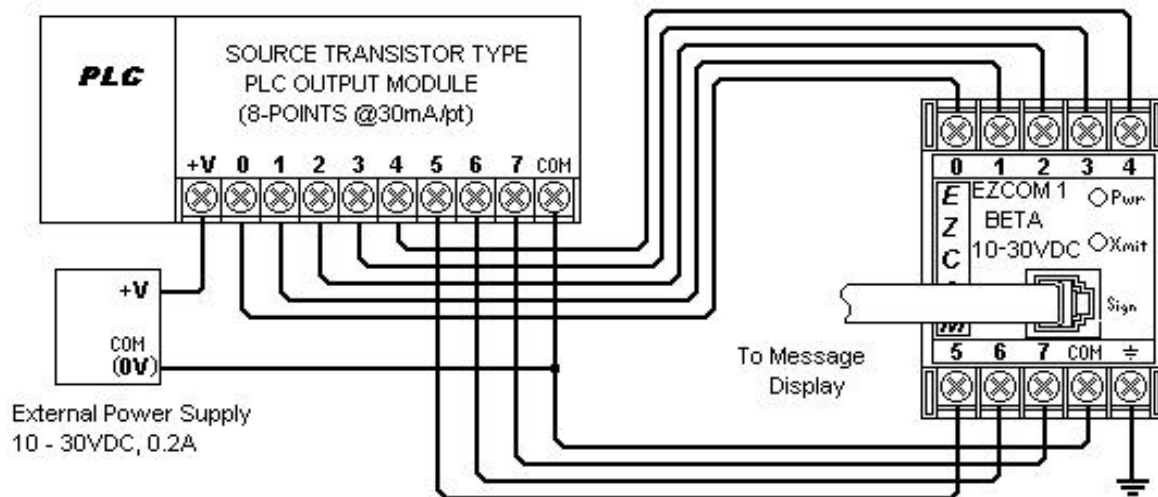

AMS Message Display Connection

1. Locate the serial ports on your sign. (Refer to Appendix J: RS232 and RS485 sign pin-outs from AMS's Network Configurations Manual - 9708-8046)

This will involve removing a cover on the following models: BIG-DOT, 215, BETABRITE

2. Identify the RS232/RS485 port (BETABRITE only has 1 port)

3. Connect the ferruled end of the appropriate Display-Interface cable to the RS232/RS485 port. It should fit into the connector with an audible "click".

4. Replace the sign's Communication Port cover. (If applicable)

EZCOM-1 Interface Unit Connection

1. Mount the EZCOM-1 on standard 35mm DIN rail or by the 2 screw holes located on the base on the unit.

Using AMS cable 1088-8625, a display can be mounted up to 25' away from the EZCOM
Using AMS cable 1088-8627, a display can be mounted up to 50' away from the EZCOM

2. Connect the output terminals of the PLC according to the wiring diagram. The terminal marked "COM" is the common negative return to the PLC and the GROUND terminal is an optional earth. If used, it should be attached to the nearest earthing point.

Note: PLC Transistor Outputs should have a range of 10 - 30 VDC and be capable of sourcing at least 20mA per Output.

3. Connect the un-ferruled end of the Data Cable to the front-panel socket on the EZCOM. It should also fit into the connector with an audible "click".

WARNING : DO NOT CONNECT THE EZCOM-1 TO A TELEPHONE LINE!!!
(REFER TO WARRANTY -Note 1.)

EZCOM-1 Interface Unit Testing

Once the Installation has been completed, apply power to the PLC and the Display. The green "Pwr" LED on the front-panel of the EZCOM should now be lit. After approximately 15 seconds, the red "Xmit" LED should flash briefly and the display will be "blanked".

If the "Pwr" LED does not light upon the application of power, check that the data cable is connected at both ends and that it is in the correct port of the sign.

If the "Pwr" LED is ON, but there is no flashing of the "Xmit" LED after 15 - 20 seconds, return the unit for Service.

When "Run Message" commands are sent to the sign, three short "beeps" should be heard from the sign. If the sign beeps but nothing is displayed, there is no file at the selected location. Silence the "beeping" by turning off the sign's sound with the IR Loader.

OPERATION

Now the unit has been installed and is working properly, the PLC should have its program modified to drive the outputs to select the pre-programmed messages. This document assumes the Operator is familiar with both the programming of the ALPHA sign using the IR Program Loader or the AlphaNet for Windows software, as well as the appropriate PLC programming.

The PLC must output a pair of BCD (Binary Coded Decimal) digits to enable the EZCOM-1 to communicate with the ALPHA display. The following table shows the PLC output bits, which must be set to create the BCD digits.

Table of Binary Coded Decimal Outputs from PLC

PLC OUTPUT TERMINALS								BCD DIGIT VALUE
7	6	5	4	3	2	1	0	
OFF	OFF	OFF	OFF	OFF	OFF	OFF	OFF	0
OFF	OFF	OFF	OFF	OFF	OFF	OFF	ON	1
OFF	OFF	OFF	OFF	OFF	OFF	ON	OFF	2
OFF	OFF	OFF	OFF	OFF	OFF	ON	ON	3
OFF	OFF	OFF	OFF	OFF	ON	OFF	OFF	4
OFF	OFF	OFF	OFF	OFF	ON	OFF	ON	5
OFF	OFF	OFF	OFF	OFF	ON	ON	OFF	6
OFF	OFF	OFF	OFF	OFF	ON	ON	ON	7
OFF	OFF	OFF	OFF	ON	OFF	OFF	OFF	8
OFF	OFF	OFF	OFF	ON	OFF	OFF	ON	9
OFF	OFF	OFF	ON	OFF	OFF	OFF	OFF	10
OFF	OFF	ON	OFF	OFF	ON	OFF	ON	25
OFF	ON	ON	ON	OFF	OFF	ON	ON	73
ON	OFF	OFF	ON	ON	OFF	OFF	ON	99

Note: 4-bit values for A,B,C,D,E and F are invalid.

Note: BCD values of 95 to 99 are Special Functions.

Refer to Appendix A - EZCOM Filename Quick Reference for explanations.

Warranty

Except as described below, the manufacturer warrants the product to be free from defects in materials and workmanship in normal use for a period of twelve (12) months after date of purchase. Should the product fail to perform according to this warranty at any time during the warranty period, except as provided for below, the Manufacturer, or its authorised Service Centres will, at the Manufacturer's discretion, repair or replace the product at no additional charge.

The Warranty does not cover loss or damage which occurs in shipment, or which is due to :-

1. Improper installation or maintenance, misuse neglect or any cause other than ordinary commercial applications, including without limitation, "Acts of God"
2. Adjustment, repair or modification by other than the Manufacturer or Authorised Service Centre.
3. Improper environment, excessive or inadequate heating or air-conditioning, electrical power failures, surges or other irregularities.

A receipt or copy of the Invoice with the date of purchase or delivery from the Supplier of the unit is required before any Warranty Service can be rendered.

APPENDIX A
Multiple AMS Message Display Connection
 EZCOM-1 ALPHA ONLY**

The EZCOM-1 ALPHA draws its power from the RS232/RS485 or TTL/RS485 port on the first sign to which it is connected via the 1088-8625 or 1088-8627 cable. Additional signs can be connected in either of the 2 ways shown:

Option 1. Using AMS RS485 cables (1088-8624 or 1088-8636)

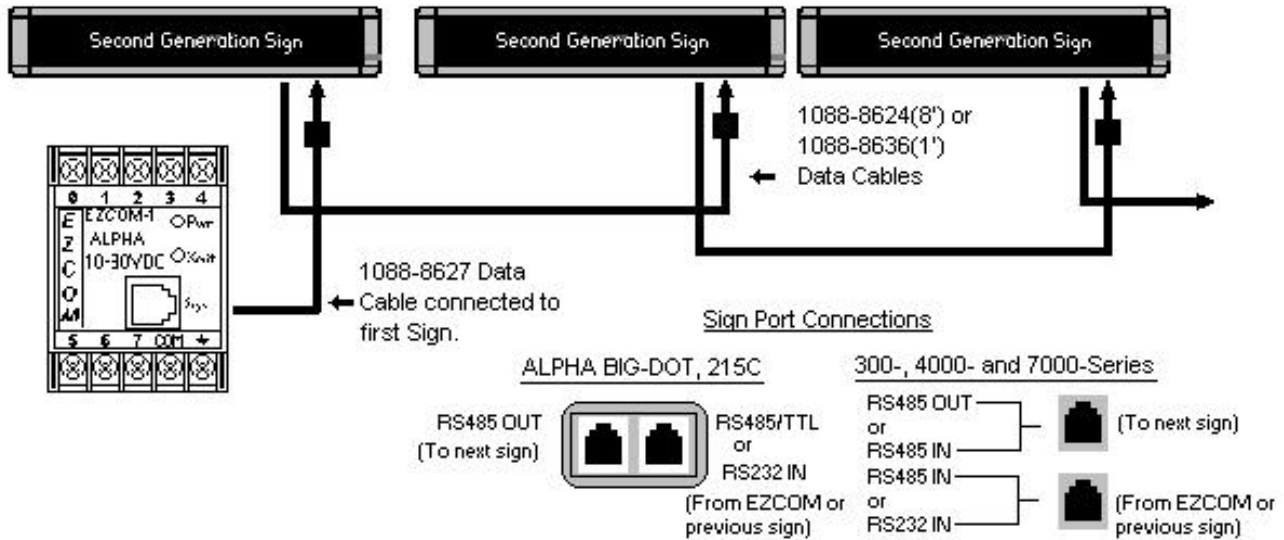

Option 2. Using AMS RS485 Network Adaptor Module (P/No. 1088-9103 or 4331-0602) and STP cable

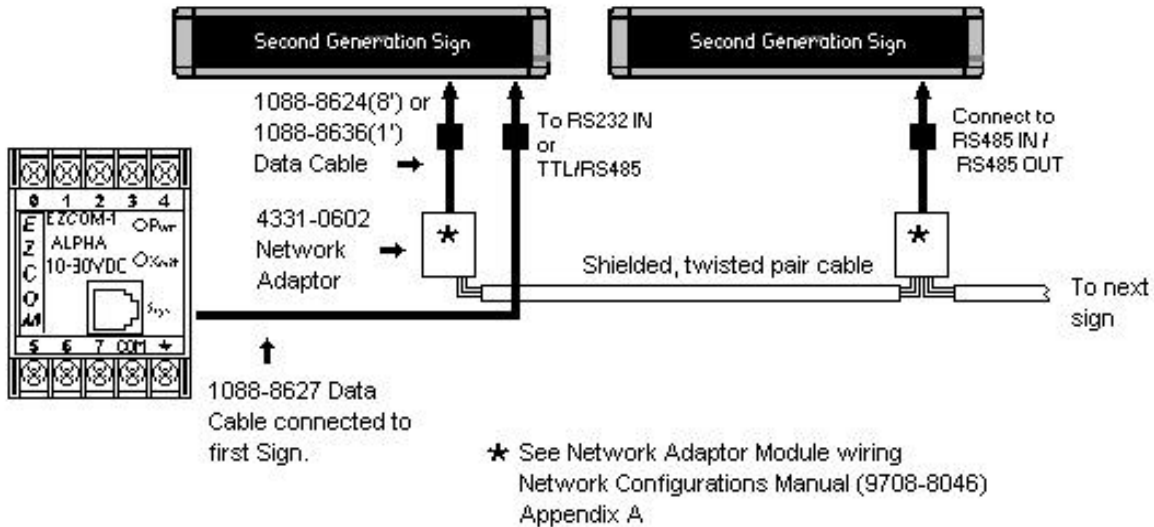

Notes:

- **ONLY** ALPHA-Series Signs can be run this way. This configuration is not possible for **BETABRITE**.
- For the **EZCOM** to be located >50' from the first sign, the EZCOM may need an external supply. (Consult Factory)
- For longer distances, an End-Of-Line Terminating Resistor (Part No. 1088-9107) may need to be placed in the RS232/RS485 socket of the last sign. (Option 2)

Appendix B
EZCOM FILENAME REFERENCE SHEET

The table below is intended for use by the Operator. It provides a quick look-up table for pre-programmed messages. Filenames marked with an asterisk (*) are not available through the IR Program Loader. Copy as many as are required.

BCD VALUE	Filename	Message Stored at this location
0	<SPACE>	
1	!	
2	"	
3	#	
4	\$	
5	%	
6	&	
7	'	
8	((*)	
9) (*)	
10	*	
11	+	
12	,	
13	-	
14	.	
15	/	
16	0	
17	1	
18	2	
19	3	
20	4	
21	5	
22	6	
23	7	
24	8	
25	9	
26	:	
27	;	
28	<	
29	=	
30	>	
31	?	
32	@ (*)	
33	A	
34	B	
35	C	
36	D	
37	E	
38	F	
39	G	
40	H	
41	I	
42	J	

43	K	
BCD VALUE	Filename	Message Stored at this location
44	L	
45	M	
46	N	
47	O	
48	P	
49	Q	
50	R	
51	S	
52	T	
53	U	
54	V	
55	W	
56	X	
57	Y	
58	Z	
59	[(*)	
60	\ (*)	
61] (*)	
62	^ (*)	
63	_ (*)	
64	'	
65	a	
66	b	
67	c	
68	d	
69	e	
70	f	
71	g	
72	h	
73	i	
74	j	
75	k	
76	l	
77	m	
78	n	
79	o	
80	p	
81	q	
82	r	
83	s	
84	t	
85	u	
86	w	
87	v	
88	x	
89	y	
90	z	
91	{ (*)	
92	(*)	

93	} (*)	
94	~ (*)	
95	(*)	
96		Display all programmed files in order
97		Display all programmed files in order
98		Display all programmed files in order
99		Blank Display (Turn all messages off)

Your Notes: